

Step #1

Flip the front half of the cover onto the back half of the cover. Unzip the back half of the cover exposing the white foam (see Fig. 1). Next, slide the aluminum plate insert inbetween the foam and the vinyl cover making sure the short edge of the aluminum plate insert is facing towards the acrylic of the spa (see Fig. 2). Make sure the leading edge of the aluminum plate inserts slide into the cover 11 inches from the back of the cover. **Note: If your spa has a 4 inch or less corner radius, insert your aluminum plate inserts 10 inches from the back edge of the cover, not 11 inches.** Once in position, re-zip the cover.

Step #2

Position the cover (in closed position) on the spa making sure that all four corners are properly positioned and square on the spa.

Step #3

Attach the Covermate Vanish XL handle to the cover mounting bracket using the supplied 1-1/4" button head socket bolt (see Fig. 3).

Step #4

Attach the Covermate Vanish XL template to the appropriate cover mounting bracket (L & R). **Note: For determining L & R bracket, see Fig. 3.** When attaching the cover mounting brackets to the side of the cover, measure 11 inches from the back edge of the cover and mark the bracket position (see Fig. 5). **Note: If your spa has a 4 inch or less corner radius, mount your cover mounting brackets 10 inches from the back edge of the cover, not 11 inches.** Next, attach the cover mounting bracket to the cover per the templates as shown, using the supplied #10 x 1" self-drilling screws (see Fig. 4). **When attaching the cover mounting brackets to the cover, make sure to put downward pressure on the bracket to avoid any tenting of the bracket on the cover.**

Step #5

Attach the Vanish XL pivot arms to the Vanish XL base mounting brackets using the supplied 2-1/4" button head socket bolts, washers & locknuts (see Fig. 6). **Note: Make sure to install the large and small pivot arm shims as shown. Make sure the pivot arms rotate freely, do not overtighten bolts.** Next, attach the rubber bumpers to the front pivot arms using the supplied #8 x 1-1/4" self-tapping screws (see Fig. 6).

Step #6

Attach the Vanish XL base/pivot arm assembly, built in step 5, to the cover mounting brackets attached to the cover using the supplied 2" button head socket bolts, washers, plastic shim washers & locknuts and let the assembly hang freely (see Fig. 7). **Note: Make sure to run the bolts from the inside out. The locknuts need to be facing outwards. Also, make sure to use the supplied plastic washers as a spacer in between the pivot arms and the Vanish XL cover mounting brackets (see Fig. 7). Do not overtighten the bolts, the pivot arms need to rotate freely.**

Step #7

Swing the Vanish XL bracket assembly up until the front and rear pivot arms make contact with each other (see Fig. 8). Attach the Vanish XL bracket assembly to the spa cabinet using the supplied #10 x 1-1/2" mounting screws. **Note: Install the bracket mounting screws from just behind the front pivot arm forward. Do not install the bracket mounting screws further back, otherwise the bracket will warp causing the lifter to not work properly (see Fig. 8).**

Step #8

To attach the shocks to the bracket assembly, partially open your vinyl cover and snap the shocks onto the ball studs (see Fig. 8). **Note: Make sure the black body of the shock is pointing towards the middle of the spa.**

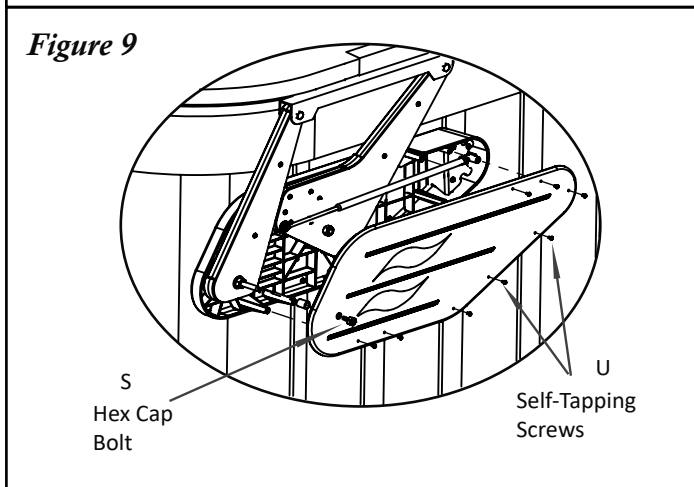
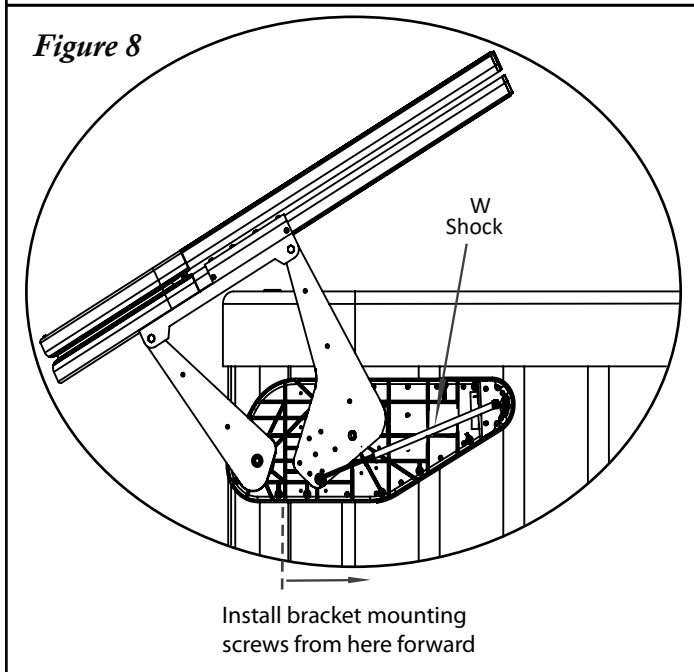
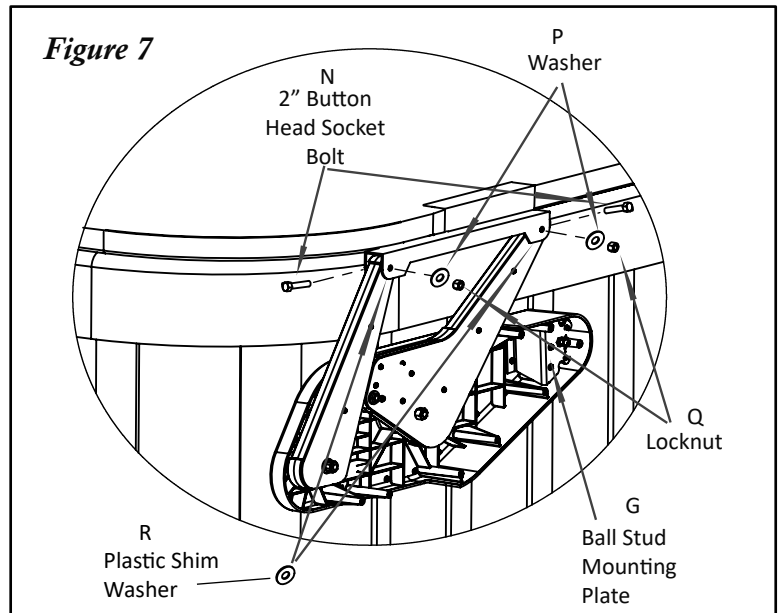
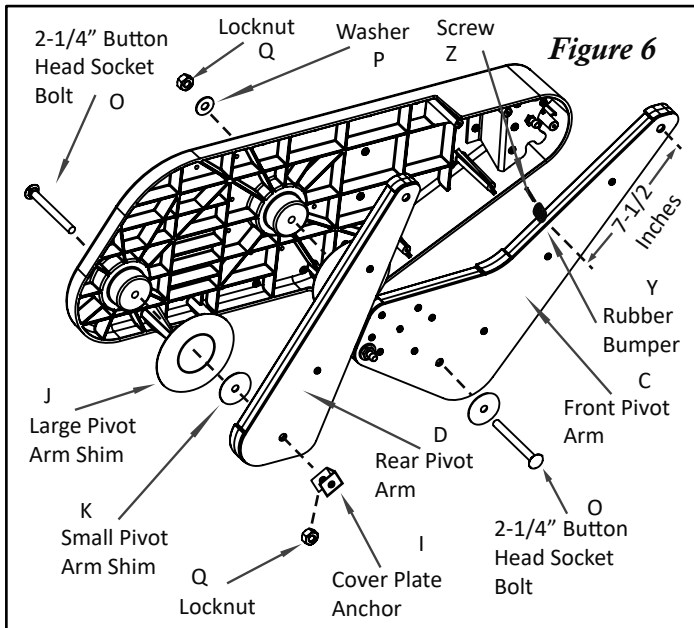

Step #9

Open the vinyl cover so it is in the fully open position. Using the supplied #10 x 1-1/2" mounting screws, finish attaching the Vanish XL bracket assembly to the spa.

Step #10

Attach the Vanish XL cover plate to the bracket assembly using the supplied #10 x 1" philips pan head self-tapping screws. Next, thread the 3/8 x 3/4" hex cap bolt through the hole in the cover plate that lines up with the rear pivot arm (see Fig. 9). **Note: Do not overtighten the hex cap bolt.**

Operation of your Covermate Vanish XL

- 1) Fold the first half of the cover off the spa. Next, lift up and push the cover back behind the spa.

ITEM	PART#	DESCRIPTION	QTY
A(L)	101733	VANISH XL BASE BRACKET (L)	1
A(R)	101734	VANISH XL BASE BRACKET (R)	1
B(L)	101756	CM VANISH XL COVER MOUNTING BRACKET (L)	1
B(R)	101757	CM VANISH XL COVER MOUNTING BRACKET (R)	1
X	102141	CM VANISH XL ALUMINUM PLATE INSERT	2
C	101737	VANISH XL PIVOT ARM - FRONT	1
D	101738	VANISH XL PIVOT ARM - REAR	1
E	101739	VANISH XL PIVOT ARM PLATE - FRONT	1
F	101740	VANISH XL PIVOT ARM PLATE - REAR	1
G(L)	101741	BALL STUD MOUNTING PLATE - LEFT	1
G(R)	101742	BALL STUD MOUNTING PLATE - RIGHT	1
H(L)	101743	VANISH XL COVER PLATE (L)	1
H(R)	101744	VANISH XL COVER PLATE (R)	1
I	101745	VANISH XL COVER PLATE ANCHOR	2
J	101746	LARGE PIVOT ARM SHIM	4
K	101747	SMALL PIVOT ARM SHIM	4
L	100244	5/16 BALL STUD	4
M	100032	5/16 NYLON LOCKNUT	4
N	101749	3/8 X 2" BUTTON HEAD SOCKET BOLT - BLACK ZINC	4
O	101758	3/8 X 2-1/4" BUTTON HEAD SOCKET BOLT - BLACK ZINC	4
P	100012	3/8 FLAT WASHER	6
Q	100011	3/8 NYLON LOCKNUT	8
R	101750	3/8 PLASTIC SHIM WASHER	8
S	101752	3/8 X 3/4" HEX CAP BOLT - BLACK ZINC	2
T	100909	#10 X 1-1/2" PHILIPS PAN HEAD MOUNTING SCREW	68
U	101873	#10 X 1" PHILIPS PAN HEAD MOUNTING SCREW - BLACK ZINC	26
V	100015	LARGE BLACK DOME CAP	6
W	101510	SHOCK - 335N	2
Y	101762	RUBBER BUMPER	2
Z	101650	#8 X 1-1/4" PHILIPS FLAT HEAD SELF-TAPPING SCREW - BLACK ZINC	2
AA	101552	COVERMATE VANISH XL HANDLE	2
AB	101751	5/16 X 1-1/4" BUTTON HEAD SOCKET BOLT	2
AC	100836	#10 X 1" PHILIPS PAN HEAD SELF-DRILLING SCREW - BLACK	8

CAUTION!

Do not use the Covermate in high wind conditions. Injury from the spa cover being blown over and impacting the spa user can occur.