

# SMARTOP

Vanish XL by Leisure Concepts

Installation Instructions - Updated as of 02/28/23

### Step #1

Position the Smartop (in closed position) on the spa making sure that all four corners are properly positioned and square on the spa.

### Step #2

Attach the handle to the EAS bracket using the supplied 5/16 x 1-1/4" button head socket bolt (see Fig. 1).

### Step #3

Attach the 2-piece arm mount to the Smartop cover using the supplied 1/4 x 3/4" flat head socket screws, 1/4 flat washers & 1/4 locknuts (see Fig. 2). *Note: The excess length of the 2-piece arm mount hangs towards the back of the spa.*

### Step #4

Attach the handle to the Smartop 2-piece arm mount using the supplied 5/16 x 1-1/4" button head socket bolt (see Fig. 2). *Note: For swim spa Smartops, attach the handle to the Smartop cover bracket using the hole closer to the back of the spa. For Smartops on standard spas, use the hole in the middle of the bracket.*

### Step #5

Attach the Vanish XL pivot arms to the Smartop using the supplied button head socket bolts and let the assembly hang freely (see Fig. 3). *Note: Make sure to run the bolts from the inside out. The locknuts need to be facing outwards. Note: The plastic shim washers have been pre-installed at the factory. Upon completion of the installation of your Smartop, any remaining plastic shim washers should be discarded. Do not overtighten bolts, the pivot arms must rotate freely.*

### Step #6

Swing the Vanish XL bracket assembly forward making sure the two pivot arms rest against each other (see Fig. 3). Attach the Vanish XL bracket assembly to the spa cabinet using the supplied #10 x 1-1/2" mounting screws. *Note: Make sure to put downward pressure on the Smartop when attaching the Vanish XL bracket assembly to the spa cabinet to ensure the Smartop is making a good seal with the acrylic of the spa.*

### Step #7

Repeat steps 2, 3, 4 & 5 for the opposite side of the spa.

### Step #8

To attach the shocks to the bracket assembly, partially open your Smartop cover and snap the shocks onto the appropriate ball studs (see Fig. 4). *Note: Make sure the black body of the shock is pointing towards the middle of the Smartop.*

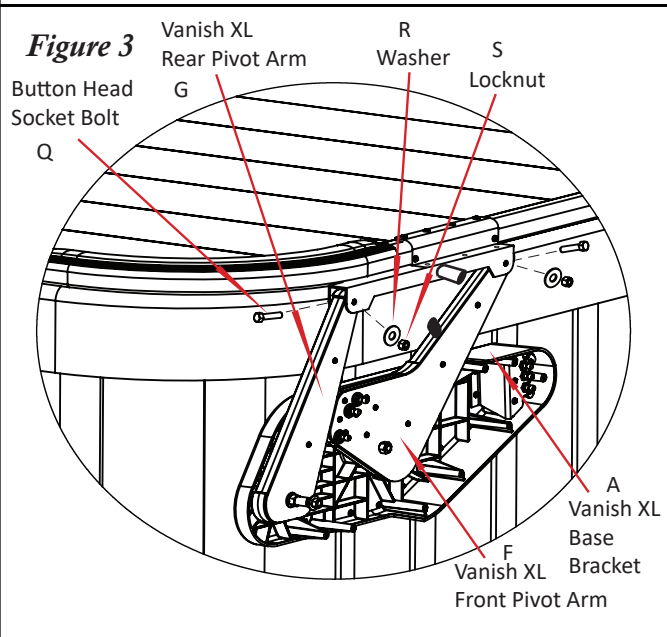
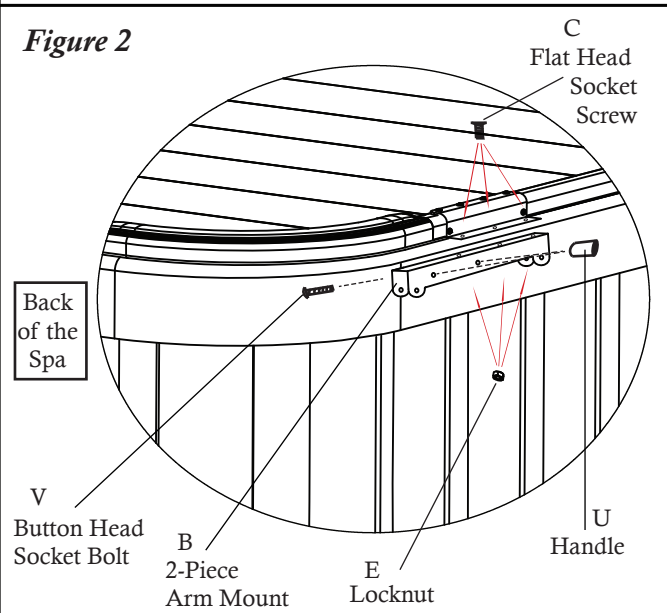
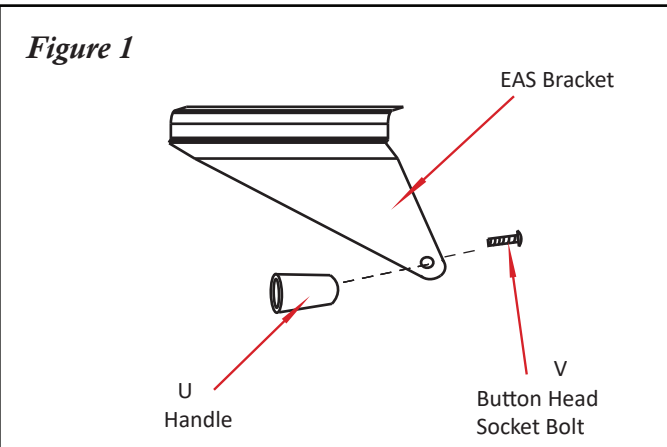
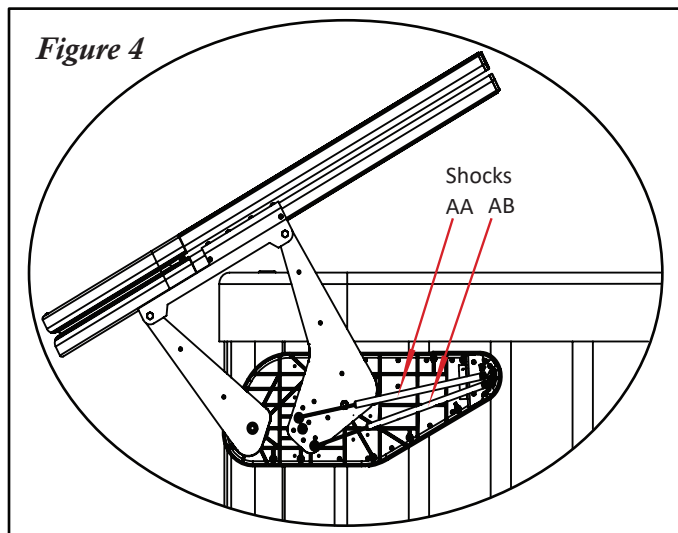

### Step #9

Open the Smartop so it is in the fully upright position. Using the supplied #10 x 1-1/2" mounting screws, finish attaching the Vanish XL bracket assembly to the spa.

### Step #10

Attach the Vanish XL cover plate to the bracket assembly using the supplied self-tapping screws. Next, thread the 3/8 x 3/4" hex cap bolt through the hole in the cover plate that lines up with the rear pivot arm (see Fig. 5). **Note: Do not overtighten hex cap bolt.**

### Step #11

Connect the Sure Lock latch to the latch catch. While pushing down on the Smartop, position the Sure Lock latch on the side of the spa and mark where the latch base rests against the spa skirting. Attach the Sure Lock latch to the spa skirting, where marked, using the supplied self-tapping screws (see Fig. 6).

### Step #12

If the thermal seal on the underside of the Smartop does not completely seal around the control panel of your spa, an additional thermal seal control pad has been included with the Smartop. Close the Smartop and determine the position of the thermal seal pad. Open the Smartop cover onto itself, dry thoroughly and remove the backing of the thermal seal pad and attach it to the underside of the Smartop in the desired position (see Fig. 7).

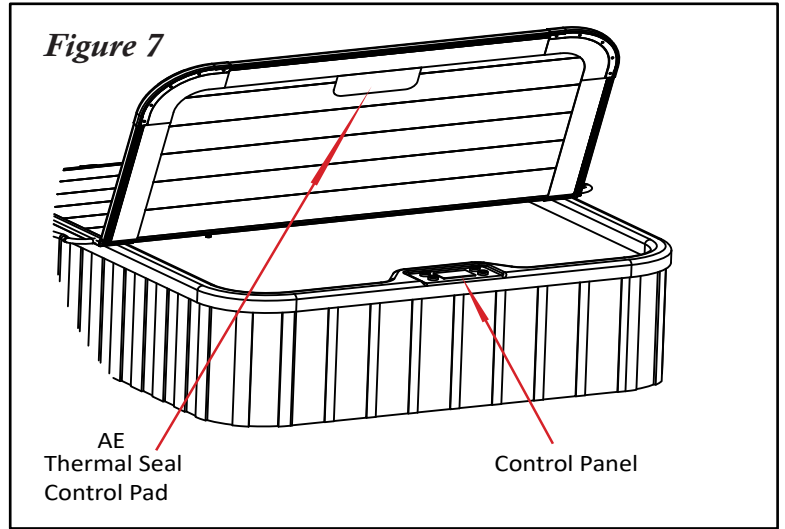

**CAUTION!** Do not use the Smartop in high wind conditions. Injury from the spa cover being blown over and impacting the spa user can occur.

## Operation of your Smartop Cover

- 1) Fold the first half of the Smartop cover off the spa. While gripping the EAS handle, motion the Smartop cover into it's vertical upright position.

ITEM	PART#	DESCRIPTION	QTY
A(L)	101733	ST VANISH XL BASE BRACKET (L)	1
A(R)	101734	ST VANISH XL BASE BRACKET (R)	1
B	102176	ST VANISH 2-PIECE ARM MOUNT	2
C	101592	1/4 X 3/4" FLAT HEAD SOCKET SCREW - BLACK	6
D	100895	1/4 FLAT WASHER - BLACK	6
E	100607	1/4 NYLON LOCKNUT	6
F	101737	VANISH XL PIVOT ARM - FRONT	1
G	101738	VANISH XL PIVOT ARM - REAR	1
H	101739	VANISH XL PIVOT ARM PLATE - FRONT	1
I	101740	VANISH XL PIVOT ARM PLATE - REAR	1
J(L)	101741	BALL STUD MOUNTING PLATE - LEFT	1
J(R)	101742	BALL STUD MOUNTING PLATE - RIGHT	1
K(L)	101743	ST VANISH XL COVER PLATE (L)	1
K(R)	101744	ST VANISH XL COVER PLATE (R)	1
L	101745	VANISH XL COVER PLATE ANCHOR	2
M	101746	LARGE PIVOT ARM SHIM	4
N	101747	SMALL PIVOT ARM SHIM	4
O	100244	5/16 BALL STUD	12
P	100032	5/16 NYLON LOCKNUT	12
Q	101749	3/8 X 2" BUTTON HEAD SOCKET BOLT - BLACK ZINC	4
R	100012	3/8 FLAT WASHER	4
S	100011	3/8 NYLON LOCKNUT	4
T	101752	3/8 X 3/4" HEX BOLT - BLACK ZINC	2
U	101596	HANDLE	4
V	101751	5/16 X 1-1/4" BUTTON HEAD SOCKET BOLT - BLACK ZINC	4
W	100909	#10 X 1-1/2" PHILIPS PAN HEAD MOUNTING SCREW	36
X	100836	#10 X 1" PHILIPS PAN HEAD MOUNTING SCREW - AL2000 BLACK	16
Z	100015	LARGE BLACK DOME CAP	6
AA	101510	SHOCK - 335N	2
AB	101390	SHOCK - 800N	2
AC	101871	SURE LOCK LATCH ASSEMBLY	2
AD	101065	#8 X 3/4" PHILIPS FLAT HEAD SELF-TAPPING SCREW - BLACK ZINC	8
AE	101079	THERMAL SEAL CONTROL PAD	1
AF	101078	LOCK	1
AG	101762	RUBBER BUMPER	2
AH	101650	#8 X 1-1/4" PHILIP FLAT HEAD SELF-TAPPING SCREW - BLACK ZINC	2

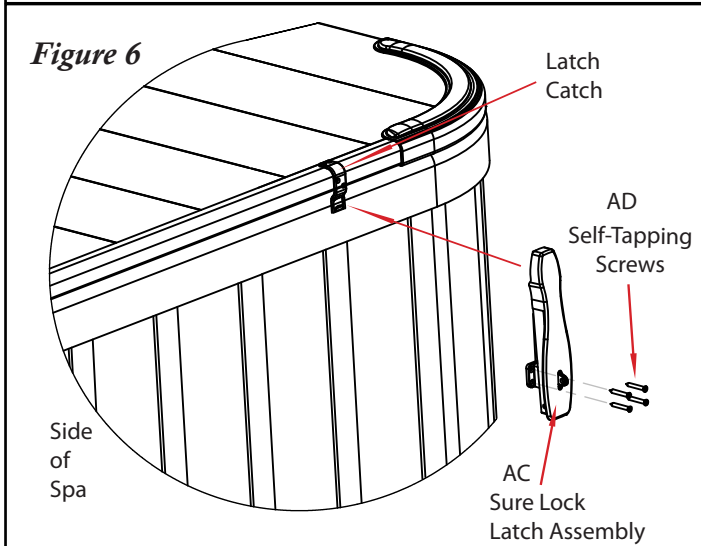
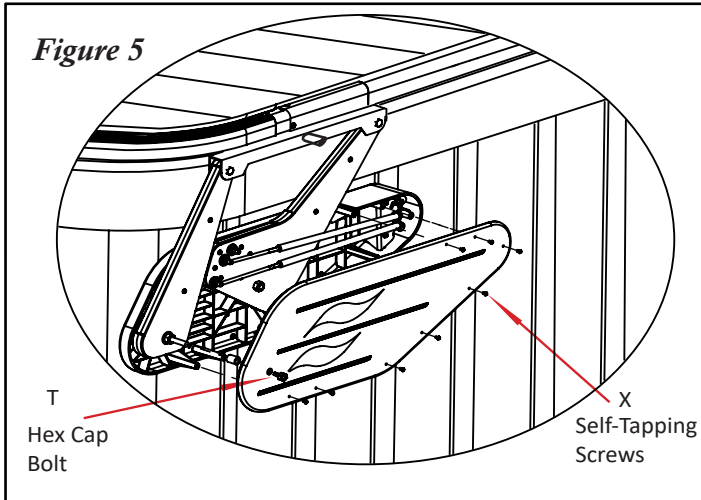

For additional information on our Smartop product, please visit our website: [www.smartopspacover.com](http://www.smartopspacover.com)