

Figure 1



Foam

Figure 2



D
Aluminum Plate Insert

Figure 3

Q
CM Zero-R
Cover Bracket
Template

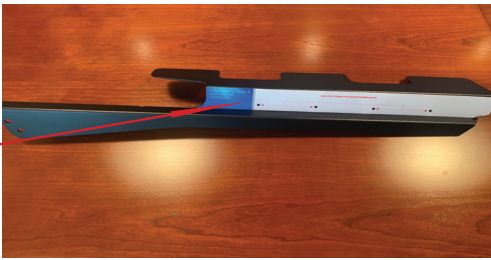
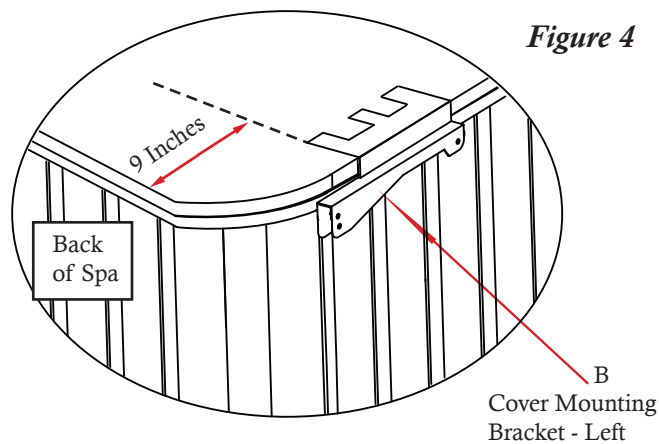
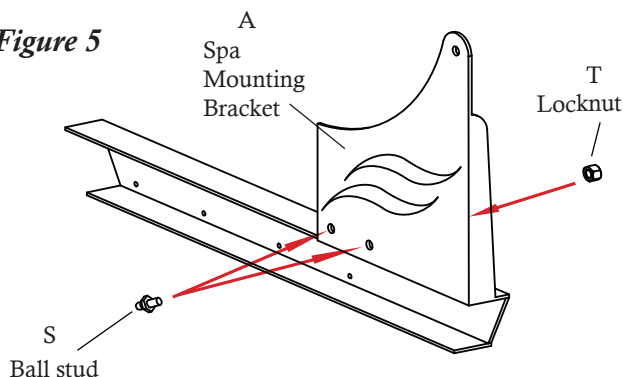

Figure 4



B
Cover Mounting
Bracket - Left

Figure 5



Step #1

Flip the front half of the cover onto the back half of the cover. Unzip the back half of the cover exposing the white foam (see Fig. 1). Next, slide the aluminum plate insert inbetween the foam insert and the vinyl cover making sure the short edge of the aluminum plate insert is facing towards the acrylic of the spa (see Fig. 2). Make sure the leading edge of the aluminum plate inserts slide into the cover 9 inches from the back of the cover. **Note: If your spa has a 2 inch or less corner radius, slide your aluminum plate inserts into the cover 7 inches from the back edge of the cover, not 9 inches.** Once in position, re-zip the cover.

Step #2

Position the cover (in closed position) on the spa making sure that all four corners are properly positioned and square on the spa.

Step #3

Attach the CM Zero-R template to the appropriate cover mounting bracket (L & R). **Note: For determining L & R bracket, see Fig. 3.** When attaching the cover mounting brackets to the side of the cover, measure 9 inches from the back edge of the cover and mark the bracket position (see Fig. 4). **Note: If your spa has a 2 inch or less corner radius, mount your cover mounting brackets 7 inches from the back edge of the cover, not 9 inches.** When standing in front of the spa, the cover mounting bracket-left will be attached to the left side of the cover. Attach the cover mounting brackets to the cover, per the templates as shown, using the supplied #10 x 1" self-drilling screws (see Fig. 3). When attaching the cover mounting brackets to the cover, make sure to put downward pressure on the bracket to avoid any tenting of the bracket on the cover.

Step #4

Attach the ball stud to the CM Zero-R spa mounting bracket in the hole closest to the back of the bracket (see Fig. 5). **Note: Once final installation has been completed, if the cover doesn't lift off the spa easily, start by moving one of the ball studs on one side of the spa to the front hole and re-attach the shocks. If the cover still doesn't lift off the spa easily, move the ball stud on the other side of the spa and re-attach the shocks.**

Step #5

Insert the 3/8 x 1-3/4" button head socket bolt into the top hole in the back of the cover mounting bracket. Make sure to install the rubber stop on the button head socket bolt once you insert the bolt through the outside flange of the cover mounting bracket. Secure the 3/8 washer and locknut to the opposite end of the button head socket bolt (see Fig. 6). **Note: Do not over-tighten locknut.**

Step #6

Attach the CM Zero-R cabinet mounting bracket to the CM Zero-R cover mounting bracket, in the bottom hole, using the supplied 3/8 x 1-3/4" button head socket bolt, washer and locknut (see Fig. 7). **Note: Make sure to use the plastic spacers on either sides of the CM Zero-R cabinet mounting bracket where the bolt goes through. You will use 7 plastic spacers for each side of the spa.**

Step #7

While pressing downward on the CM Zero-R cover mounting bracket, swing the CM Zero-R cabinet mounting bracket up until it is parallel with the spa acrylic and attach to the spa cabinet using the supplied #10 x 2" mounting screws (see Fig. 7).

Step #8

Slide the filler bracket in behind the spa mounting bracket and attach to the spa cabinet using (3) #10 x 2" mounting screws (see Fig. 8). Attach the spa mounting bracket to the filler bracket using (4) #10 x 1" self-drilling screws (see Fig. 8).

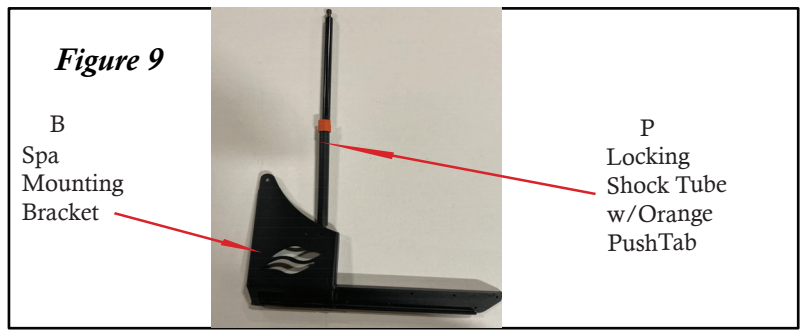
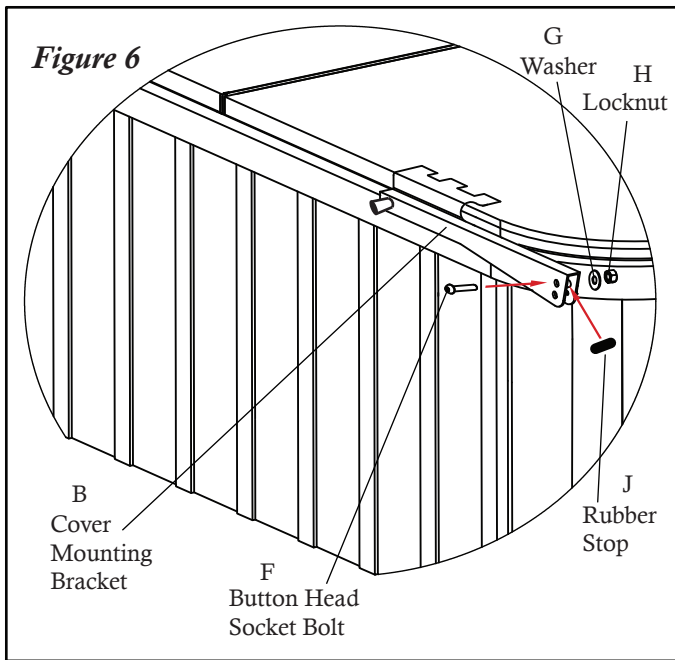

Step #9

Attach the shock to the ball stud on the spa mounting bracket. *Note: The portion of the shock with the shock tube and the orange push tab is what gets mounted on the spa mounting bracket (see Fig. 9).*

Step #10

Gently raise the cover into the upright position, making sure to keep a firm grip on the cover and attach the shocks to the CM Zero-R cover mounting bracket ball stud. Next, attach the “Push to Release” sticker to the shock directly under the orange push tab.

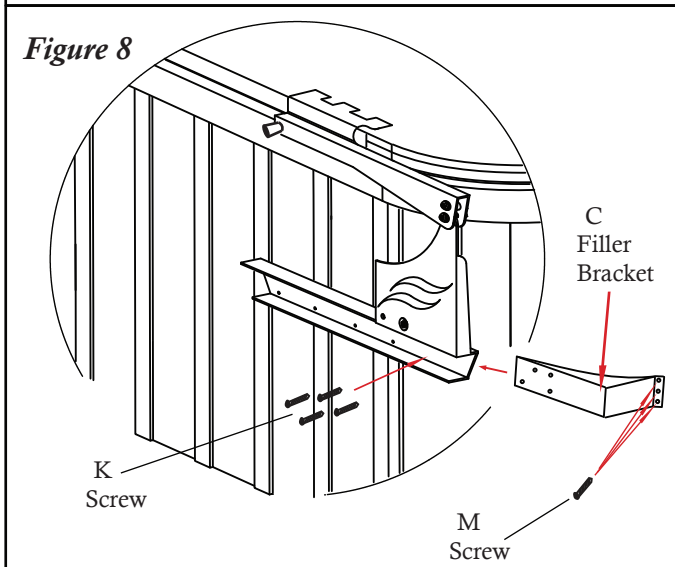
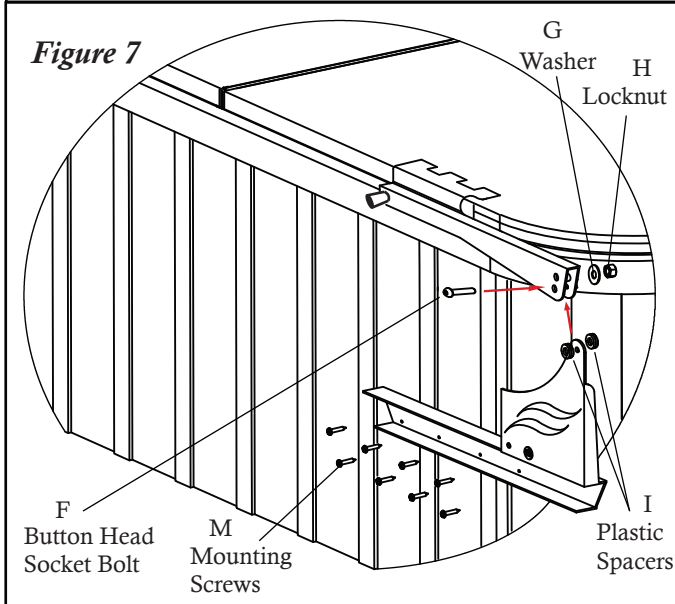

Operation of the Covermate Zero-R

1. Fold the first half of the spa cover off the spa. Gripping the foam grip, motion the spa cover into its vertical upright position.
2. **Important:** *When closing the spa cover, always make sure to unlock the shock by pushing on the unlock tube that says “Push to Release” before pulling the Covermate down to prevent possible lift damage.*

CAUTION!

Do not use the Covermate in high wind conditions. Injury from the spa cover being blown over and impacting the spa user can occur.

ITEM	PART#	DESCRIPTION	QTY
A(L)	101990	CM ZERO-R SPA MOUNTING BRACKET (L)	1
A(R)	101991	CM ZERO-R SPA MOUNTING BRACKET (R)	1
B(L)	101994	CM ZERO-R COVER MOUNTING BRACKET (L)	1
B(R)	101995	CM ZERO-R COVER MOUNTING BRACKET (R)	1
C(L)	100577	CM ZERO-R FILLER BRACKET - 460 (L)	1
C(R)	100578	CM ZERO-R FILLER BRACKET - 460 (R)	1
D	102146	CM ZERO-R ALUMINUM PLATE INSERT	2
F	101749	3/8 X 1-3/4" BUTTON HEAD SOCKET BOLT - BLACK ZINC	4
G	100951	3/8 WASHER - BLACK ZINC	4
H	100838	3/8 LOCKNUT - BLACK ZINC	4
I	101877	PLASTIC SPACER - 3/8 X 1/8"	14
J	101885	RUBBER STOP - 1-1/8"	2
K	101996	#10 x 1" PHILIPS PAN HEAD SELF-DRILLING SCREW	16
M	100359	#10 X 2" PHILIPS PAN HEAD MOUNTING SCREW	26
N	100016	SMALL BLACK DOME CAPS	42
O	101997	SHOCK	1
P	102128	SHOCK - LOCKING	1
Q(L)	102144	CM ZERO-R COVER BRACKET TEMPLATE (L)	1
Q(R)	102144	CM ZERO-R COVER BRACKET TEMPLATE (R)	1
S	100244	5/16 BALL STUD	4
T	100032	5/16 NYLON LOCKNUT	4
U	100034	BLACK HEX DOME CAP	2