

**Step #1**

Position the spa cover (in closed position) on the spa making sure that all four corners are properly positioned and square on the spa.

**Step #2**

Using the supplied #10 x 5/8" self-tapping screws, attach the left and right brackets to the left and right corner filler pieces (See Fig. 1). **Note: Only insert the back four screws at this time. Important: Bracket mounting kit required for J-445. See instructions in kit P/N 6473-558.**

**Step #3**

With the bracket attached to the filler piece, place the assembly directly under the lip of the acrylic spa surface. Position the assembly to the contour of the cabinet corner so the straight edge of the bracket is parallel to the spa side. Once the proper assembly location has been determined, use the remaining #10 x 1" screws and the #10 X 1-1/2" screws to finish attaching the bracket assembly to the spa (See Fig. 2).

**Step #4**

Install the ball studs on each mounting bracket (See Fig 4a). **Note: Make sure the ball is pointing towards the spa.**

**Step #5**

Starting with the left side first, lay the long end of the cover support arm on the top of the cover, lying parallel to the spa cover hinge about 1/2" away. Slide the U-shaped retainer clip between the two cover halves with the horizontal part touching the underside of the cover hinge. **Note: Do not insert the U-shaped retainer clip in between the seams of the spa cover (See Fig. 3).** With the left support arm lying on the cover, slide the center coupler piece over the long end of the left cover support arm. Next, slide the long end of the right support arm into the center coupler and slide the U-shaped retainer clip between the two cover halves.

**Step #6**

Slide the left and right pivot arms onto the short end of the support arms (See Fig. 3). **Note: Do not insert self-tapping screws at this time, this will be completed in step #8.** Next, connect the pivot arms to the brackets (See Fig. 4c). Be sure to run the hex cap bolts as pictured. **Lightly tighten the nut so the pivot can move freely.**

**Step #7**

Next, install the ball studs to the left and right pivot arms. Place the two hex dome caps over the ball stud locknuts. **Note: Be sure that the ball is pointing away from the spa (See Fig. 5).**

**Step #8**

With the coupler piece and support arms adjusted properly (about 1/2" away from cover hinge and centered on spa), using the #10 self-tapping screws, fasten the support arms to the pivot arms and the center coupler piece to the support arms (See Fig. 6). **Note: Be sure to rotate the coupler piece so that the inserted screws are at a horizontal angle with the screw head facing the back of the spa.**

**Step #9**

Using the Covermate, lift the cover off the spa and place it in the upright position. Snap the gas shocks on the ball studs. **Note: Be sure to install gas shocks with the black body on top (See Fig. 7 for complete look). Note: You may need to pull back on the pivot arm a small amount to be able to attach the shock to the pivot arm.**

**Step #10**

Attach the provided 3 hook TowelMate on the preferred side of your Covermate by simply snapping it into place and inserting the middle self-tapping screw (See Fig. 8).

## Operation of the Covermate III Jacuzzi 435/445

1. Fold the first half of the spa cover off the spa. Gripping the foam grip, motion the spa cover into its vertical upright position.

2. **Important:** When closing the spa cover, always make sure to unlock the shock by pushing on the orange stop before pulling the Covermate down to prevent lift damage.

### CAUTION!

Do not use the Covermate in high wind condition. Injury from the spa cover being blown over and impacting the spa user can occur.

Figure 5

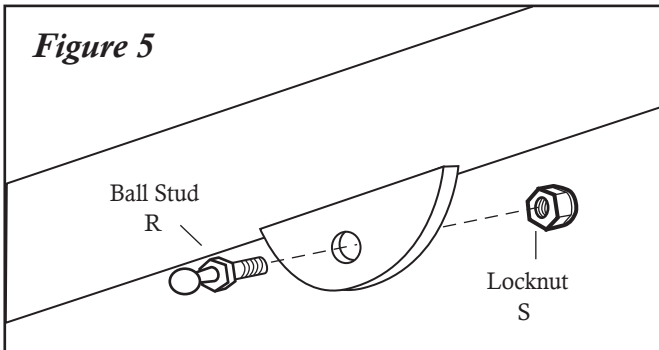

Figure 6

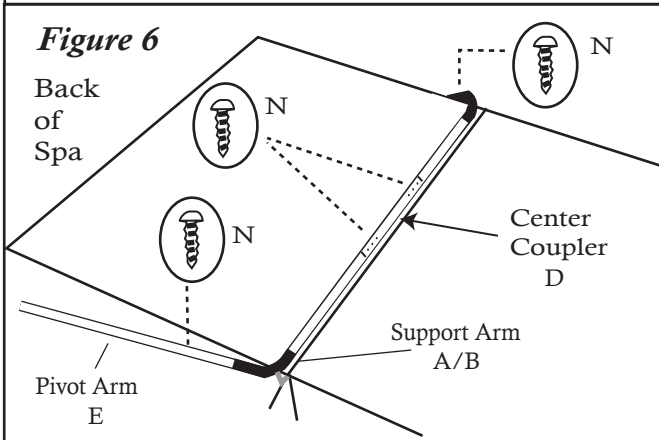

Figure 7

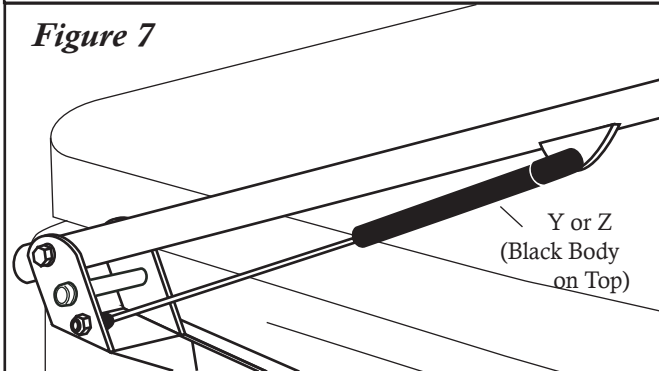
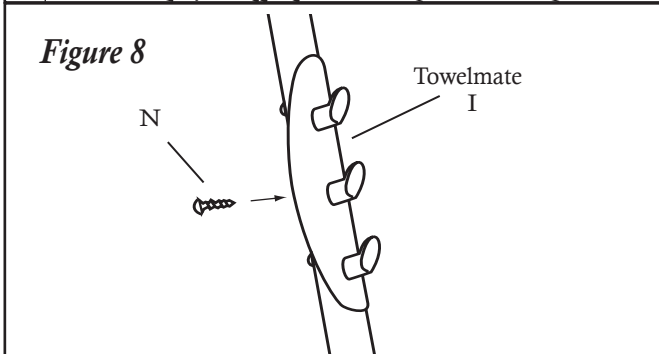

Figure 8



ITEM	PART#	DESCRIPTION	QTY
A	100029	SUPPORT ARM W/RETAINER-LEFT	1
B	100028	SUPPORT ARM W/RETAINER-RIGHT	1
C	100002	FOAM GRIP	2
D	100003	CENTER COUPLER	1
E	100022	PIVOT ARM	2
F	100344	BUSHING	4
G (L)	100551	BRACKET - LEFT	1
G (R)	100552	BRACKET - RIGHT	1
H (L)	100577	CORNER FILLER - LEFT	1
H (R)	100578	CORNER FILLER - RIGHT	1
I	100008	TOWELMATE	1
J	100015	LARGE BLACK DOME CAP	4
K	100026	3/8 X 2-3/4" HEX CAP BOLT	4
L	100011	3/8 NYLON LOCKNUT	4
M	100012	3/8 FLAT WASHER	4
N	100013	#10 X 5/8" SELF-TAPPING SCREWS	20
O	100909	#10 X 1-1/2" MOUNTING SCREWS	26
Q	100016	SMALL BLACK DOME CAP	58
R	100244	5/16 BALL STUD	4
S	100032	5/16 NYLON LOCKNUT	4
T	100033	CMIII-PLASTIC STOP	2
U	100034	HEX PLASTIC DOME CAP	4
Y	101632	SHOCK-CMIII LOCKING	1
Z	101510	SHOCK-CMIII	1
AA	100014	#10 X 1" MOUNTING SCREWS	6