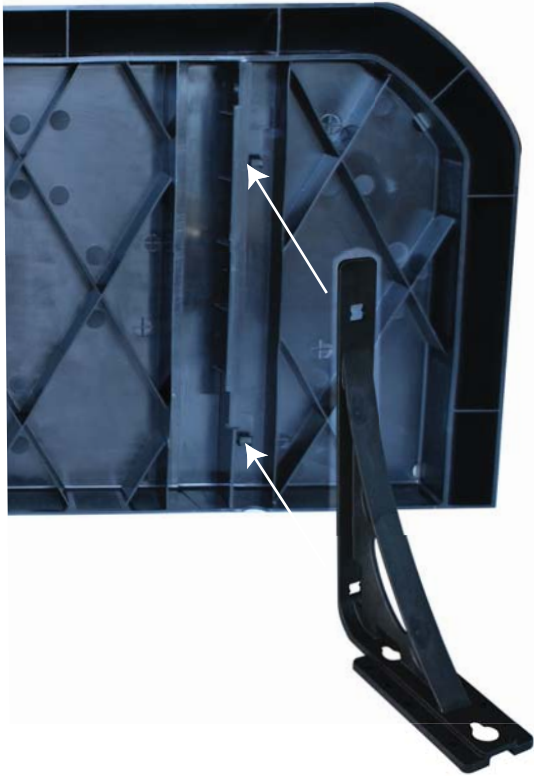

Figure 1



SmartBar Display

Assembly Instructions:

Step #1- Attach the left and right brackets to SmartBar by snapping into notched clips. Push brackets onto clips with equal hand force.

CAUTION: Excessive force can damage table clips. (See Fig. 1)

Step #2 - Slide the end of the Aluminum Tube with the silver snap button into the SmartBar Display Foot. Make sure the silver snap button pops out of the hole in the SmartBar Display Foot. (See Fig. 2).

Step #3 - Mount the Aluminum Tube between the SmartBar Mounting Brackets and the SmartBar Display Mounting Brackets by attaching with the provided #10 x 1" Philips Pan Head Wood Screws (See Fig. 2).

Figure 2

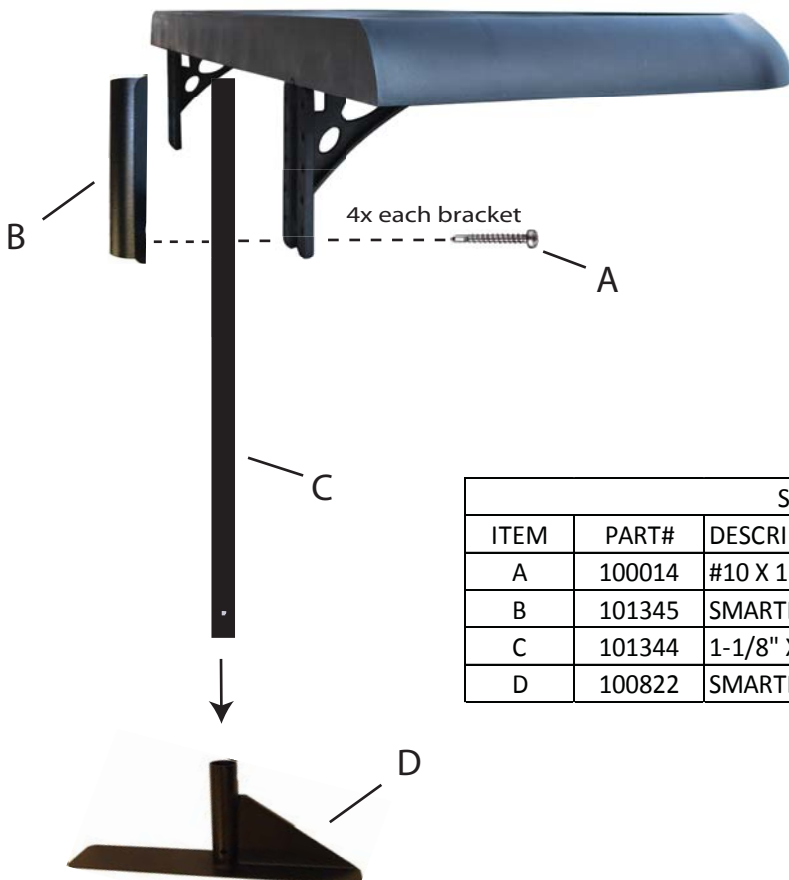

SMARTBAR DISPLAY HARDWARE			
ITEM	PART#	DESCRIPTION	QTY
A	100014	#10 X 1" PHILIPS PAN HEAD SCREW	8
B	101345	SMARTBAR DISPLAY MOUNTING BRACKET - METAL	2
C	101344	1-1/8" X 2'5" ALUMINUM TUBE	2
D	100822	SMARTBAR DISPLAY FEET	2